



PROTECTOR PROFILL MANUAL ²⁰²²



WWW.IWTM-UK.COM
T: +44 208 255 2903
E: INFO@IWTM-UK.COM

TABLE OF CONTENTS

03	DESCRIPTION & FEATURES
04	INSTALLATION
05	SIZING
07	MEASUREMENTS
11	OPERATING THE METER
12	INITIAL FILLING AND REPLACING RESIN
13	ACCESSORIES
14	VALVE KIT
15	SERVICE JOURNAL

DESCRIPTION & FEATURES

WHAT IS PROFILL?

The Protector ProFill is a range of simple, easy to use refilling and top up units for demineralised water for heating and cooling systems. Installed in line with the systems filling device, they ensure that when used with our controlled pH resin that the filling water is supplied in accordance with the VDI 2035 standard.

The range has 4 different sizes, to accommodate your system requirements. 4L, 12.5L, 25L and 50L.

The ProFill filters lime and aggressive substances such as sulphates, nitrates and chlorides out of the fill water. The appliance uses a mixed bed ion exchanger to provide demineralised water for any system size. This method does not emit any chemical additives into the water. The appliance operates without an external power connection.

The resin beads have two types of ion exchange with the untreated water. As the untreated water passes through the ProFill, positively charged ions from the water will swap with positive hydrogen ions on the resin (cation exchange).

Similarly, negative ions in the untreated water will swap with negative hydroxyl ions on the resin beads (anion exchange)

The ions will be exchanged until none is left in the water other than hydrogen and hydroxyl, making H₂O, demineralised water.

VDI 2035, SWKI Directive BT102-01 and other European standards state that water for filling heating systems should generally be demineralised for low salt operation. Practical experience has shown that even at a low hardness level, modern appliances such as wall mounted gas boilers, heat pumps and solar thermal systems can suffer damage from limescale deposits.

Compared to water that has been softened, demineralised water no longer contains any salts. Its electrical conductivity is extremely low, allowing it to act as a corrosion inhibitor.

IN LINE WITH APPLICABLE STANDARDS & GUIDANCE

It has long been clear to experts in the field that fully demineralised water is ideal for filling heating systems and that this will extend the service life of all components. Today, this technology is so user friendly and affordable that it recommends itself for practical application.

The process of full demineralisation is therefore ideal for ensuring that the water quality requirements of the following directives and standards are met:

- VDI Guideline 2035
- SWKI BT 102-01
- ÖNORM 5195-1
- DIN50930
- CIBSE Heat Network Code of Practice + Heat Network Design Guide

INSTALLATION

Protector ProFill can operate at up to 10 bar and is therefore suitable for making a permanent connection between the mains supply and the heating system.

Depending on national or local regulations, a direct connection may be subject to technical conditions which must be observed.

TYPICAL PROFILL INSTALLATION BEFORE PU, PU-DEGASSER OR SPILL UNIT

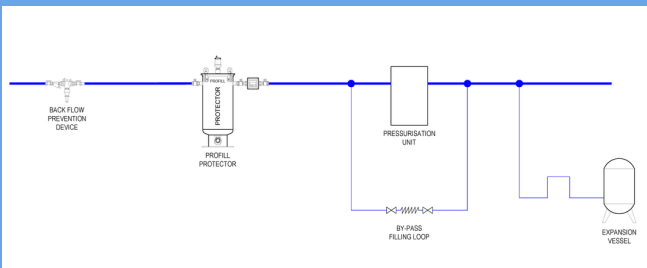

SAFETY INSTRUCTIONS:

The regulations of the water utility must be observed when connecting directly to the mains supply (e.g. system separator to DIN EN 1717).

After use, valves to the heating system and mains supply must be closed.



TYPICAL PROFILL INSTALLATION AFTER THE PU

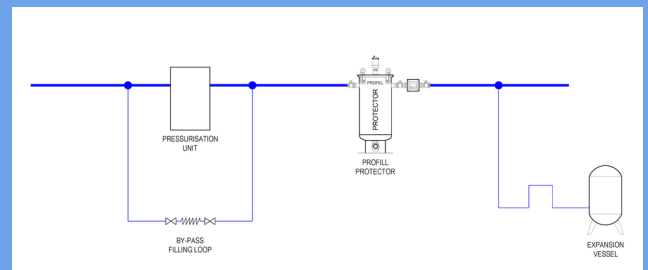

INSTALLING CONNECTIONS

- 2 pc 3/4" M x F Union Isolation Valve
- 2 pc 3/4" M x 1" Union Isolation Valve
- 3/4" F x F Isolation Valve
- Conductivity Meter



SIZING

ProFill Unit	Max Pressure	Max Temp	Delivery Capacity	Height	Overall Width	Empty Weight	Shipping Weight
ProFill 4l	10 bar	95°C	10 l/min	570 mm	369 mm	20 kg	23 kg
ProFill 12.5l	10 bar	95°C	20 l/min	726 mm	420 mm	22 kg	26 kg
ProFill 25l	10 bar	95°C	20 l/min	828 mm	474 mm	28 kg	32 kg
ProFill 50l	10 bar	95°C	20 l/min	1283 mm	474 mm	38 kg	44 kg



SIZING

SIZING GUIDE REQUIREMENTS

A ProFill should ideally be sized to accommodate 1% of the system water volume being replenished per annum for a good heating or cooling installation. The size will depend on the incoming water hardness where the ProFill is being installed. The annual fill rate of the system can be more than 1% in some circumstances and this will affect the selection as a larger unit may be required to accommodate system issues. You can find your water company and then your water hardness guide from your local water provider.

<https://www.water.org.uk/advice-for-customers/find-your-supplier/>

	2 °dH	7 °dH	15 °dH
ProFill 4	3,333	952	666
ProFill 12	10,000	2,857	1,333
ProFill 25	20,000	5,714	2,666
ProFill 50	40,000	11,428	5,332

Table showing what the approximate filling capacity in litres is with different water hardness in degrees German °dH , for the ProFill range.

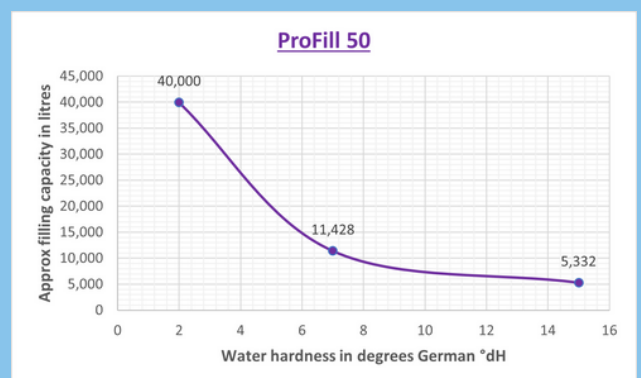
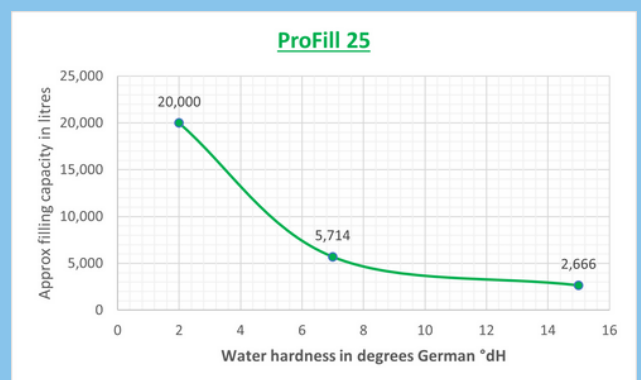
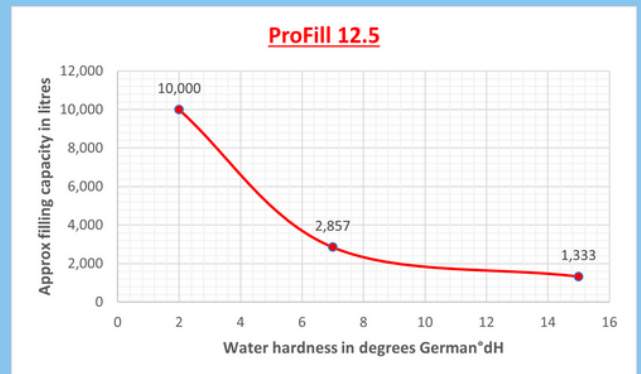
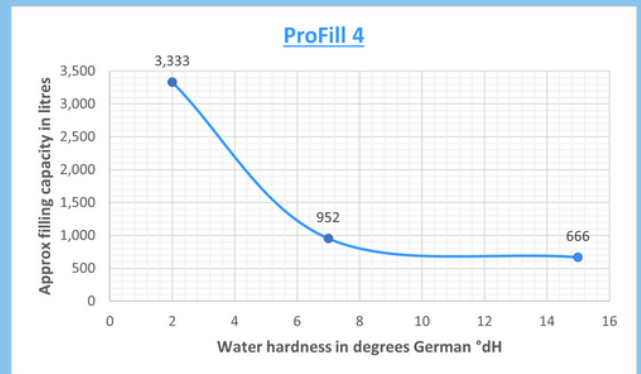

MEASUREMENTS

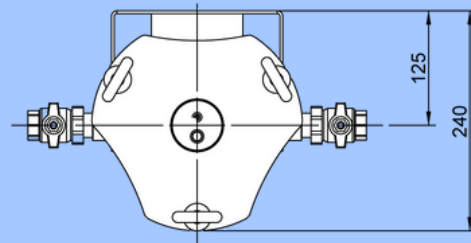
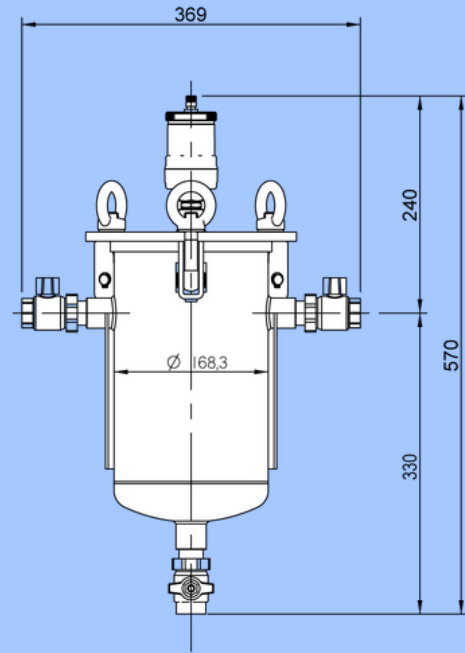
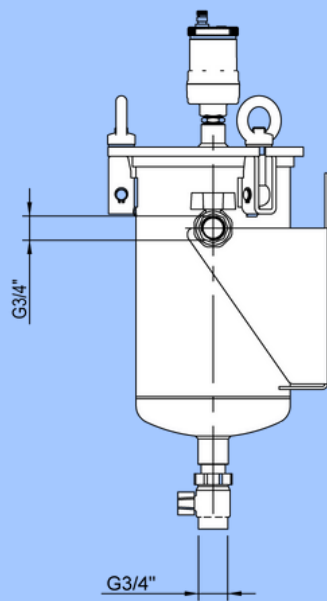

MEASUREMENTS

PROFILL 12.5L:

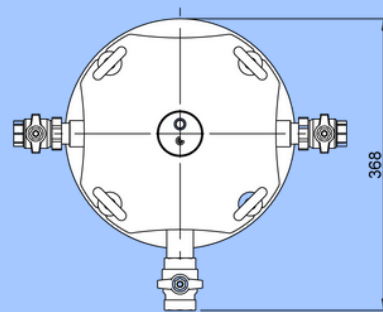
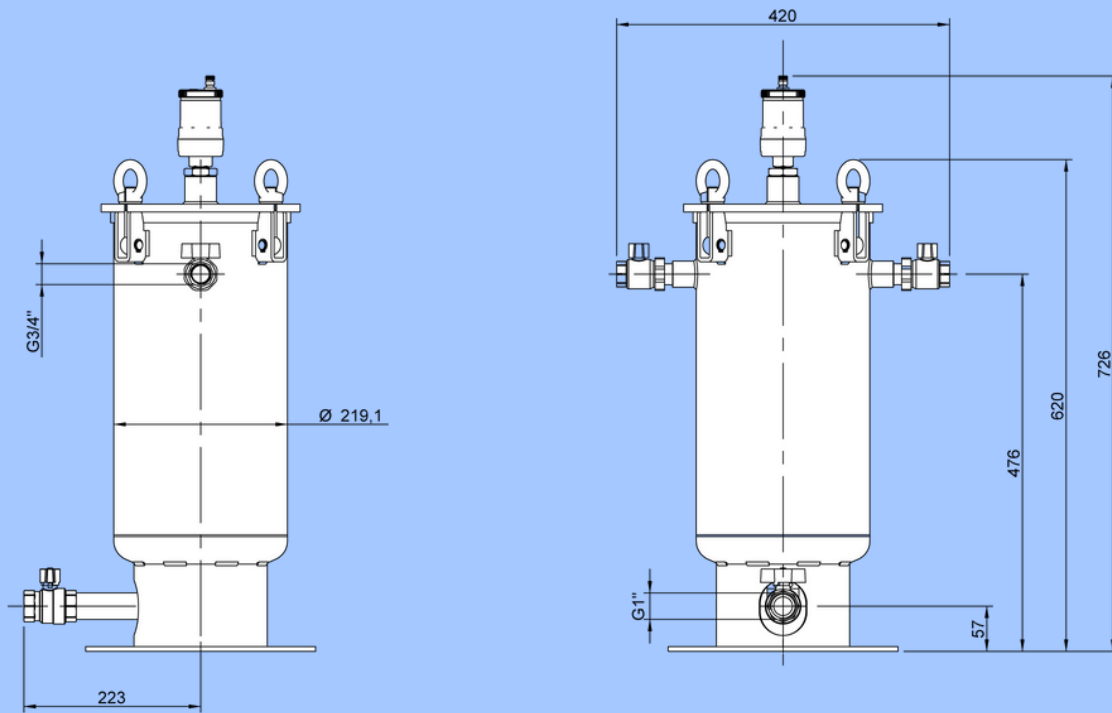

MEASUREMENTS

PROFILL 25L:

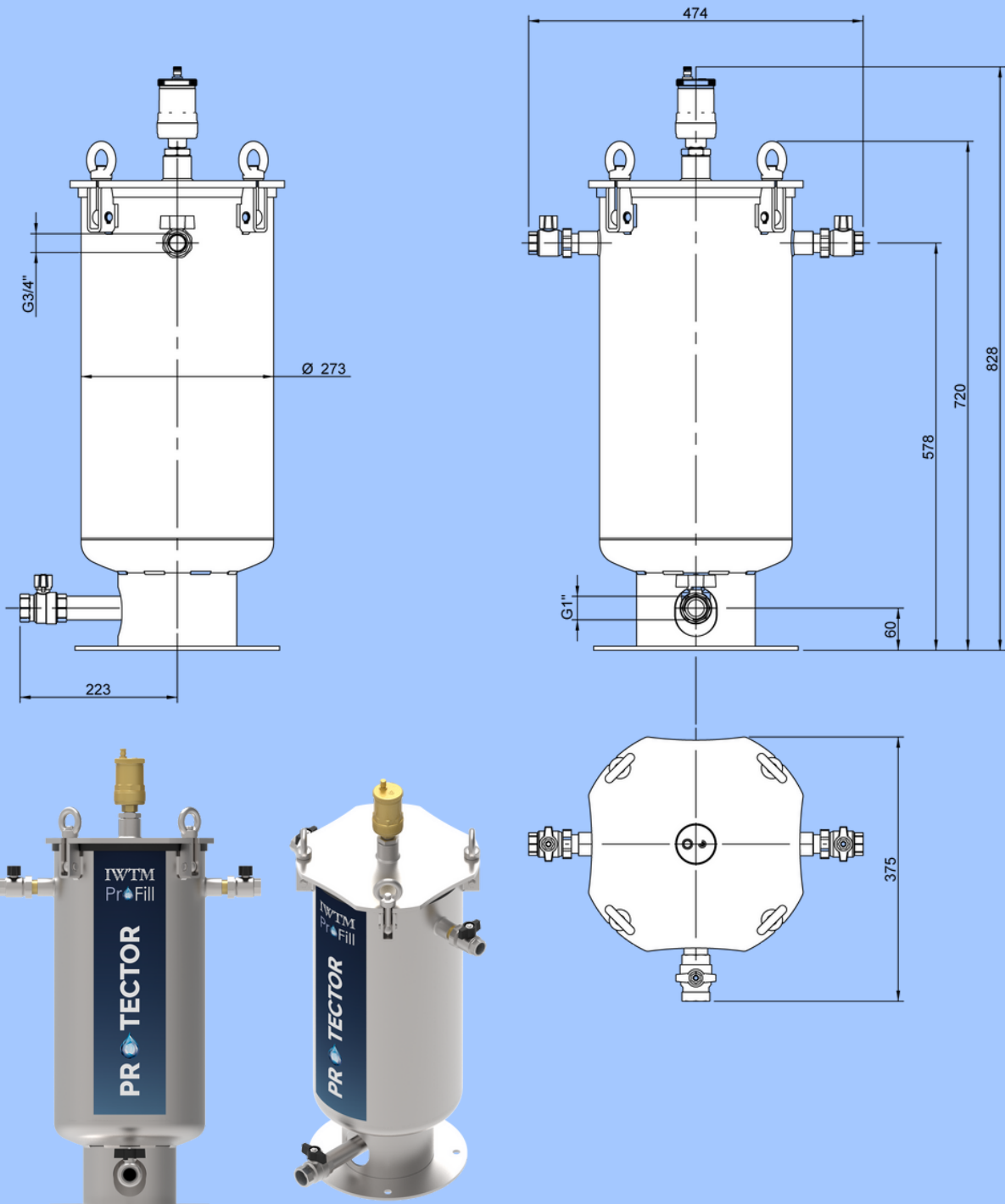

MEASUREMENTS

PROFILL 50L:

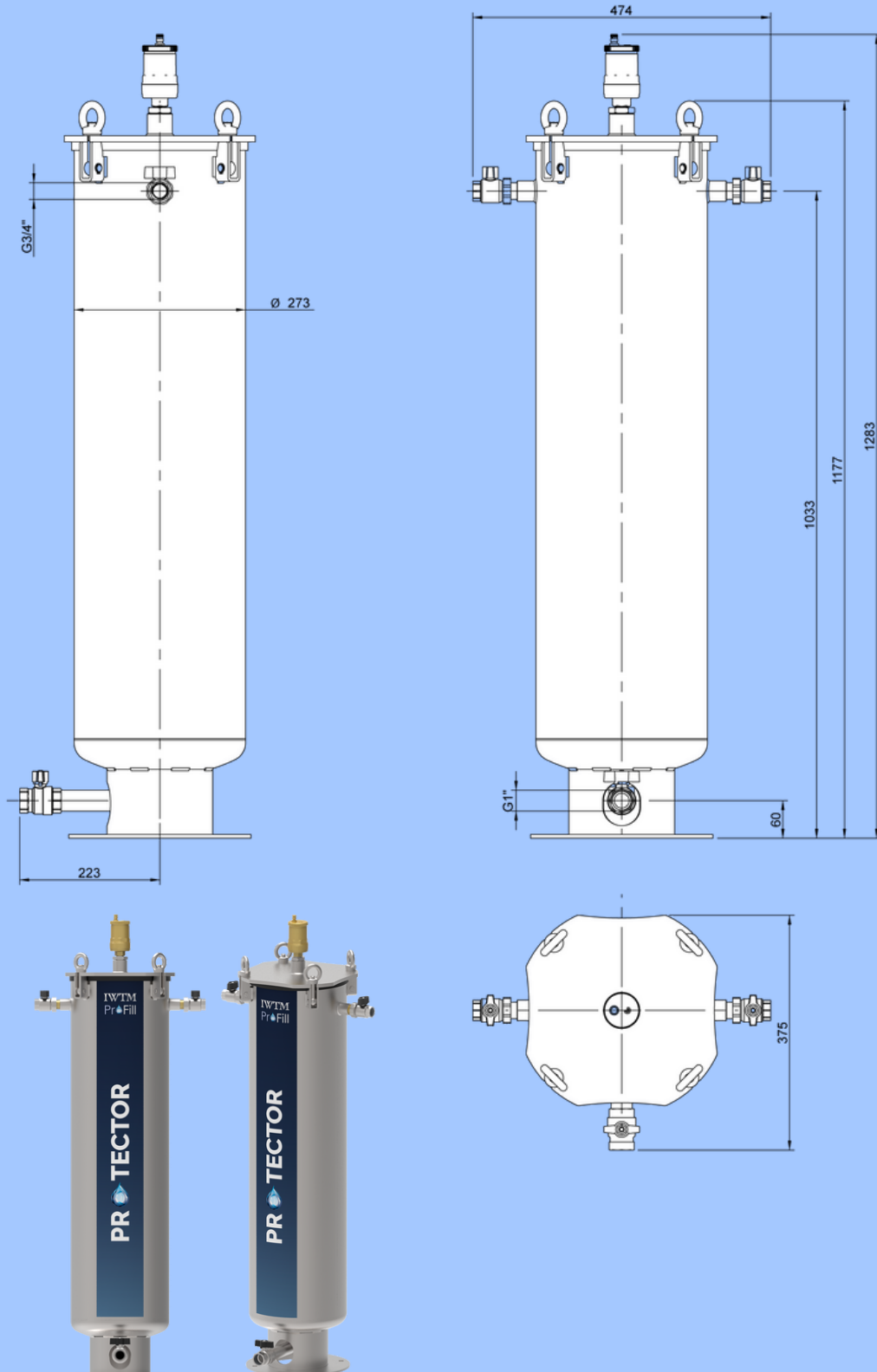

OPERATING THE COMBINED METER

The combined meter is battery-operated. It measures the flow rate in l/min, the total volume in litres and the concentration of dissolved minerals (electrical conductivity), either in micro siemens or TDS. In addition, a limit can be set for the maximum concentration of minerals tolerated in the demineralised water (ProFill outlet). The limit and flow rate total can both be reset.

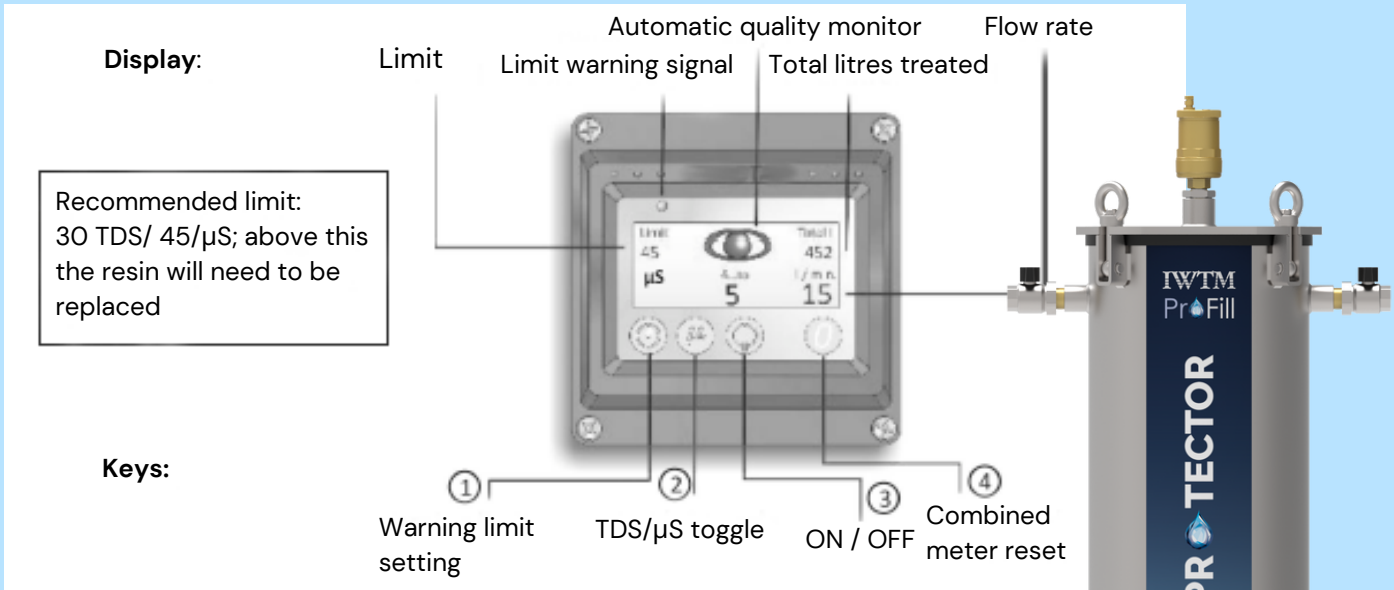

1 Every time this key is pressed, the limit is increased by 10 TDS or 15 μS/cm. Pressing the key for 3 seconds resets the limit to zero. Programming the limit ensures that a warning is issued when the ion exchange resin is spent.

2 This key can be pressed at any time to switch between TDS (total dissolved solids) and electrical conductivity. Both are units of measurement for minerals dissolved in water. Most European component manufacturers use the unit of measurement μS/cm (micro siemens).

3 If the ON key is pressed once, the water quality is measured for 10 seconds and compared to the set limit. The measured value is shown. If it is above the limit, the LED glows red; if it is below, the LED glows green while the measurement is being taken. If required, the measurement can be repeated manually.

Auto mode: If the ON key is pressed twice the combined meter begins automatic monitoring. The eye symbol appears to indicate that monitoring has been enabled. In auto mode, the meter only takes measurements when water is actually passing over it. If the water draw-off is interrupted, the meter continues to show the last captured value.

While water is being drawn off, the combined meter measures the water quality every 40 litres. If the limit is exceeded in two successive measurements, the display continuously flashes red. This indicates that the ion exchange resin is spent and needs replacing. If the ON key is pressed for a third time, the meter exits auto mode

4 Pressing the reset key for 3 seconds resets the overall total on the meter. This is recommended every time the resin is replaced, as it gives a reference point for the remaining capacity of the ion exchange resin.

When the combined meter displays the symbol indicating a battery change is due: Carefully unscrew the front and replace the batteries. 3 x AAA.



INITIAL FILLING & REPLACING THE RESIN

INITIAL FILLING

1. Undo eye bolts and remove the lid and seal.
2. Pour in the new resin. Replace the seal ensuring there is no resin on the seal.
3. Replace the lid and tighten eye bolts.
4. Reset the meter to 0.
5. Open the inlet valve and automatic air vent. When all air is dispensed open the outlet valve.
6. Check the lid is sealed and water tight.



REPLACING THE RESIN

1. Close ball valve in the outlet, connect a hose at the drain valve and route into the supplied collection sack; flush out the resin at mains pressure. Close the inlet valve and drain water, and close drain valve.
2. Continue by following the steps from 'Initial Filling'

ACCESSORIES

Part No.	Description
ProFill - Complete Units	
FTPFOFO04	PROFILL 4L WITH VALVE KIT AND FLOW METER 3/4", AISI 304
FTPFOFO01	PROFILL 12.5L WITH VALVE KIT AND FLOW METER 3/4", AISI 304
FTPFOFO02	PROFILL 25L WITH VALVE KIT AND FLOW METER 3/4", AISI 304
FTPFOFO03	PROFILL 50L WITH VALVE KIT AND FLOW METER 3/4" , AISI 304
ProFill - Valve Kit	
AMKITOO45	PROFILL VALVE KIT 3/4"
ProFill - Spare Parts	
CDGRN0003	HOUSING GASKET Ø168,3 (EPDM) - 4L
CDGRN0004	HOUSING GASKET Ø219.1 (EPDM) - 12.5L
CDGRN0005	HOUSING GASKET Ø273 (EPDM) - 25L & 50L
CASCM0016	AIR VENT
101540	FLOW METER 3/4"
ProFill - Ion Exchange Resin	
101651	PH REG RESIN HIGH ANION 12.5L
101650	PH REG RESIN HIGH ANION 4L

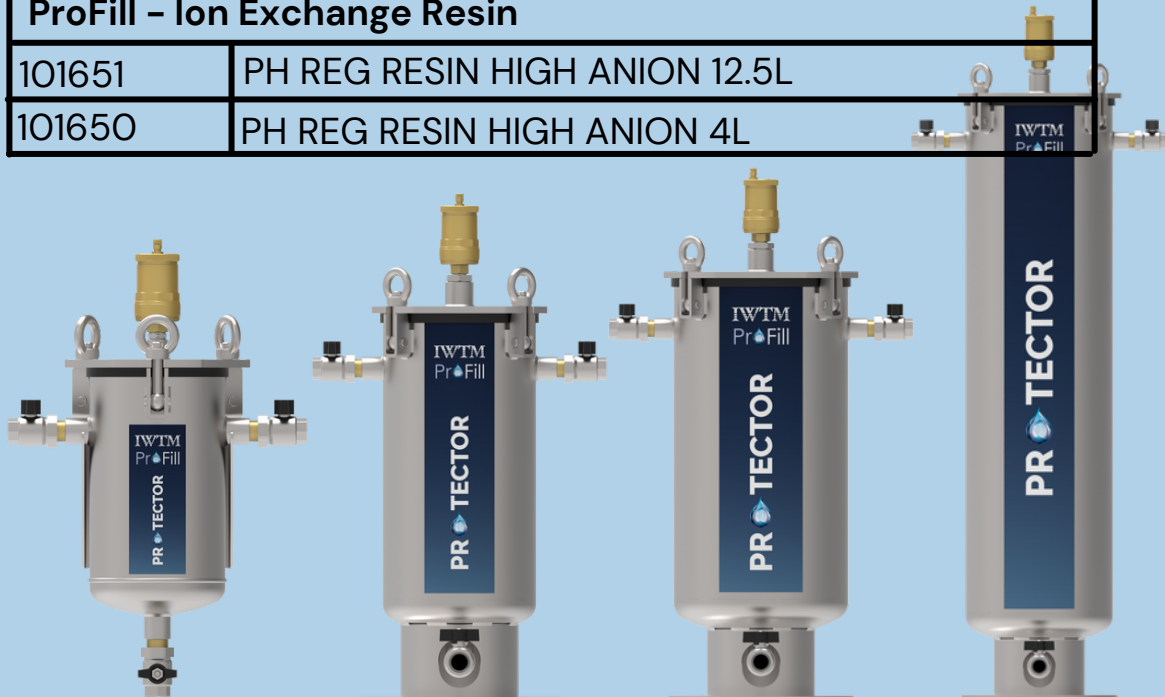

VALVE KIT

The ProFill is supplied with the following valve kit which is packed inside the main ProFill box.

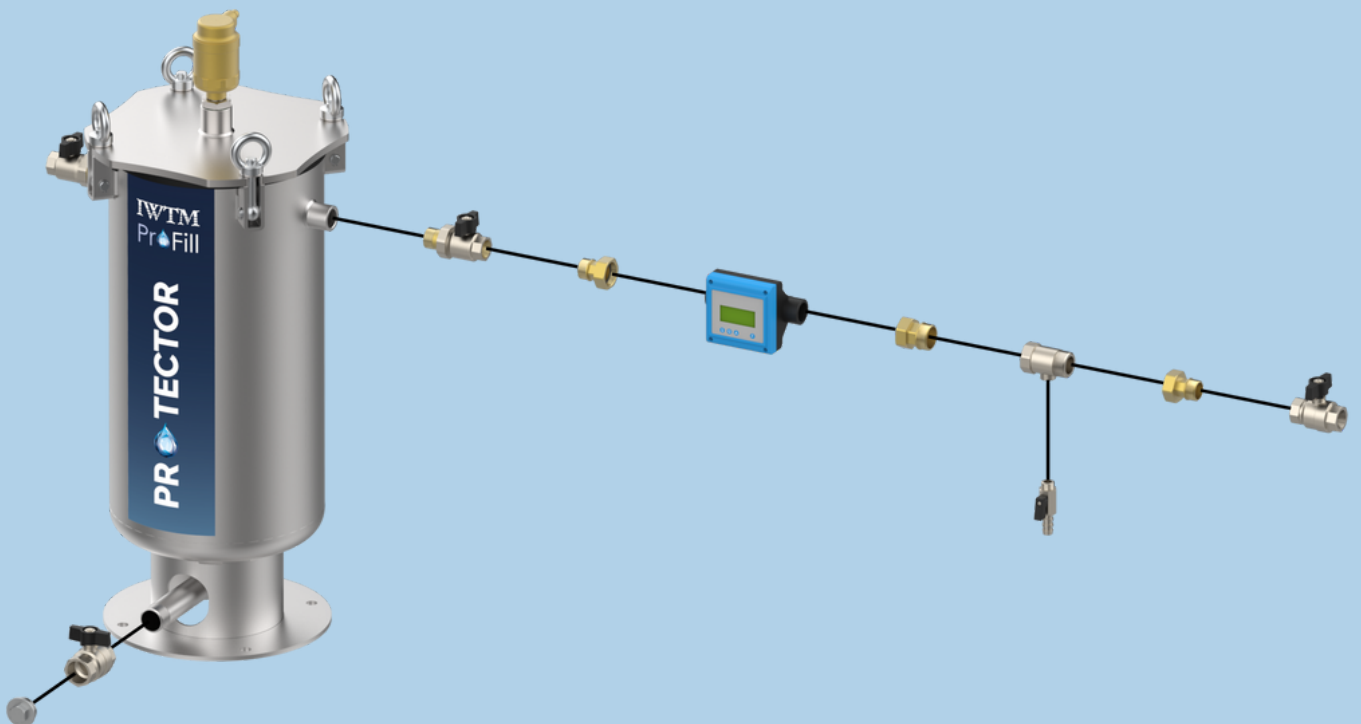



Founded in 1992, IWTM have been working with chemical free water treatment using electrochemistry for over 30 years and have offices in Norway, UK, Finland, Sweden, Canada, USA and a worldwide presence in the Marine sector.

We have developed models specifically suited to the higher demands of the marine industry operating at higher pressures and higher temperatures. The marine products are provided worldwide on the world's largest cruise ships working with the leading operators in this sector.

Having secured DNV approval in 2003, we are still the only chemical free water treatment manufacturer to have this certification and approval. DNV is a globally leading quality assurance and risk management company operating in more than 100 countries.

The IWTM Protector™ is our most recently developed product. The Protector range is now available to our land-based customers.

Version 2 : December 2022

In line with continued product development we reserve the right to make any changes to this document without any given notice.

PROTECTOR

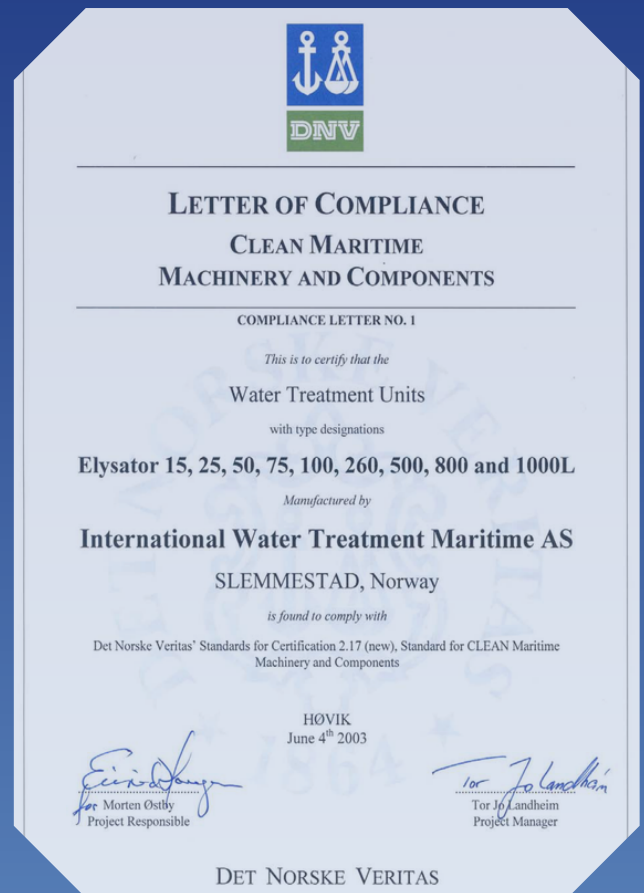

SUTTON BUSINESS CENTRE
RESTMOR WAY
WALLINGTON SM6 7AH

WWW.IWTM-UK.COM
T: +44 208 255 2903
E: INFO@IWTM-UK.COM